

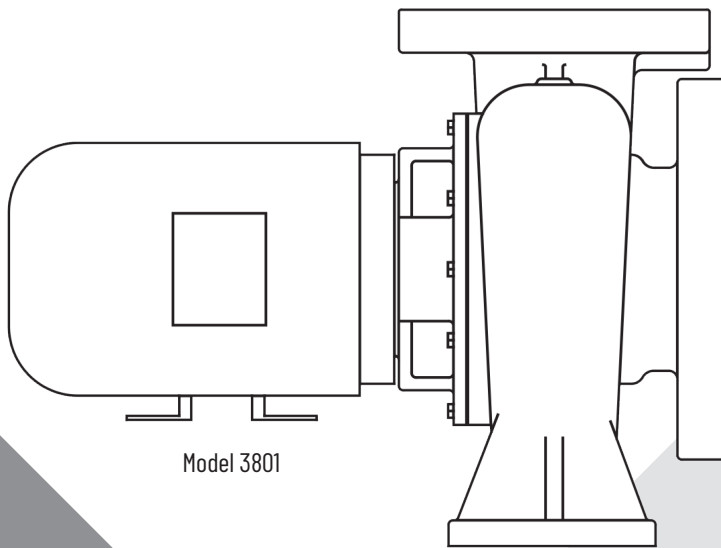

END SUCTION PUMPS

3801 ♦ 3804



Model 3801

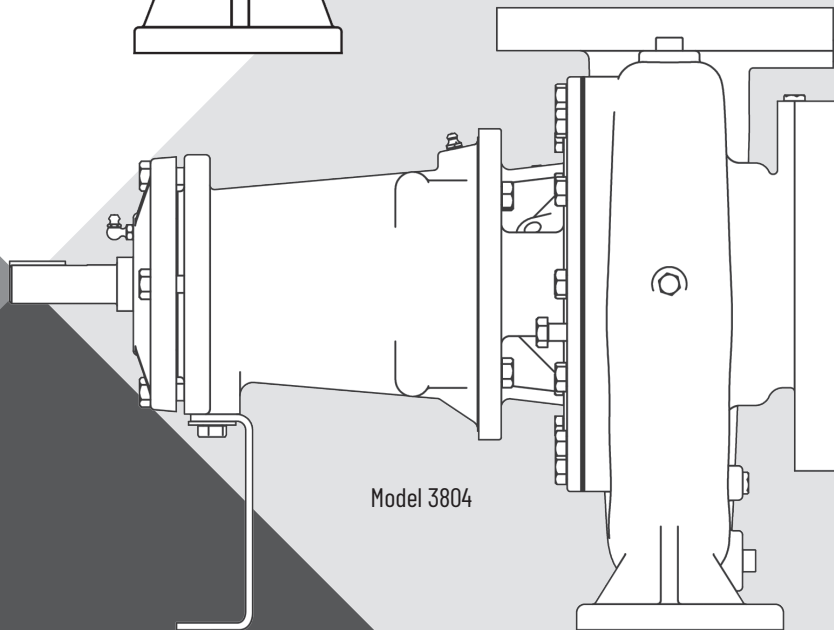

Model 3804

INSTALLATION AND OPERATION MANUAL

pentair.com

TABLE OF CONTENTS:

SECTION.....	PAGE
General Information.....	3
Transport and Storage.....	4
Product Description	5
Pump Installation.....	6-12
Pump Operation.....	13-15
Pump Maintenance and Service	16-20
Troubleshooting Guide.....	21-22
Assembly Exploded View	23-24
Part List.....	25
Standard Limited Warranty	26

GENERAL INFORMATION

NOTICE to the installer: Please make sure you provide this manual to the owner of the equipment or to the responsible party who maintains the system.

This manual contains important information for the safe use of Pentair Aurora* 3800 End Suction Pumps. Read this manual completely before using this product. DO NOT DISCARD OR LOSE THIS MANUAL.

Pentair Aurora 3804 Series pumps are frame mounted. They feature high efficiency, rugged construction, foot mounted volutes with back pullout power frames, center drop out spacer couplings (optional) and regreasable ball bearings. The pump's stainless steel fitted construction is suitable for unheated domestic, fresh water, condensate, boiler feed water, pressure boosting and hydronic coiling and/or heating.

SAFETY

Explanation of Designations

⚠ DANGER warns about hazards that will cause serious personal injury, death or major property damage if ignored.

⚠ WARNING warns about hazards that can cause serious personal injury, death or major property damage if ignored.

⚠ CAUTION warns about hazards that will or can cause minor personal injury or property damage if ignored.

NOTICE: indicates special instructions which are important but not related to hazards.

General Guidelines

- These instructions must always be kept close to the product's operating location or directly with the product.
- These instructions should be read prior to installing, operating, using and maintaining the equipment in any region worldwide. The equipment must not be put into service until all the conditions relating to safety, noted in the instructions, have been met.
- The product must not be operated beyond the parameters specified for the application. If there is any doubt as to the suitability of the product for the application intended, contact Pentair Aurora Customer Service for advice, quoting the serial number.

Personnel Qualification and Training

All personnel involved in the operation, installation, inspection and maintenance of the unit must be qualified to carry out the work involved. If the personnel in question do not already possess the necessary knowledge and skill, appropriate training and instruction must be provided. It is responsibility of owner or operator to provide training for all personnel involved in the operation, installation, inspection and maintenance of the equipment.

It is recommended that proper documentation of personnel should be maintained by the responsible part(ies).

Personnel Safety Actions

CALIFORNIA PROPOSITION 65 WARNING:

⚠ WARNING This product and related accessories contain chemicals known to the State of California to cause cancer, birth defects or other reproductive harm.

⚠ DANGER Never do maintenance work when the unit is connected to power. Always follow lock out - tag out procedures when working on equipment that may turn on.

⚠ WARNING Guards must not be removed while the pump is operational. Always follow lock out - tag out procedures when working on equipment that may turn on.

⚠ WARNING Isolate the pump from any fluid in the system and then drain any remaining fluid from the pump casing before proceeding with dismantling the pump. The appropriate safety precautions should be taken where the pumped liquids are hazardous.

⚠ WARNING Fluoroelastomers (when fitted) :When a pump has experienced temperatures over 135°C (275°F), partial decomposition of fluoroelastomers (example: Viton™) will occur. In this condition these are extremely dangerous and skin contact must be avoided.

⚠ WARNING Handling components: Many precision parts have sharp corners, thus wearing of appropriate safety gloves and equipment is required when handling these components. To lift heavy pieces above 25 kg (55 lb.) use a crane appropriate for the mass and in accordance with current local regulations.

⚠ WARNING Thermal shock: Rapid changes in the temperature of the liquid within the pump can cause thermal shock, which can result in damage or breakage of components and should be avoided.

⚠ WARNING Never apply heat to remove impeller.

⚠ WARNING Noise & vibration levels: Pentair Aurora 3800 End Suction pumps have been designed to meet the noise and vibration levels as per the Hydraulic Institute (HI) standard 9.6.4.

Electrical Safety

⚠ WARNING Sudden start-up hazard: Disconnect and lock out power source before servicing. Failure to follow these instructions could result in serious personal injury, death or property damage.

⚠ WARNING Electrical shock hazard: All electrical connections are to be made by a qualified electrician in accordance with all codes and ordinances. Failure to follow these instructions could result in serious personal injury, death or property damage.

⚠ WARNING Electrical overload hazard: Ensure all motors have properly sized overload protection. Failure to follow these instructions could result in serious personal injury, death or property damage.

High Temperature Safety

⚠ WARNING Hot surface hazard: If pumping hot water, ensure guards or proper insulation is installed to protect against skin contact with hot piping or pump components. Failure to follow these instructions could result in serious personal injury, death or property damage.

⚠ WARNING Spraying water hazard: When servicing pump, replace all gaskets and seals. Do not reuse old gaskets or seals. Failure to follow these instructions could result in serious personal injury, death or property damage.

High Pressure Safety

⚠ WARNING High pressure hazard: All the pumps are designed for specific maximum working pressure. Do not exceed this pressure. Install properly sized pressure relief valves in system. Failure to follow these instructions could result in serious personal injury, death or property damage.

⚠ WARNING Expansion hazard: Water expands when heated. Install properly sized thermal expansion tanks and relief valves. Failure to follow these instructions could result in serious personal injury, death or property damage.

TRANSPORT AND STORAGE

▲ CAUTION

- Ensure correct lubrication. See "Lubrication" on Page 13 for lubrication instruction.
- Start the pump at reduced speed or with the discharge valve partly opened. This is recommended to minimize the risk of overloading and damaging the pump motor at full or zero flow. Pumps may be started with the valve further open only on installations where this situation cannot occur. The pump discharge control valve may need to be adjusted to comply with the duty following the run-up process. See "Pump Operation" on page 13.
- Suction valves should be fully open when pump is running.
- Do not run the pump continuously outside the allowable operating region.
- Operating at a flow rate higher than normal or at a flow rate with no backpressure on the pump may overload the motor and cause cavitation. Low flow rates may cause a reduction in pump/bearing life, overheating of the pump, instability, and cavitation/vibration. Running the pump at a flow rate below the manufacturer's recommended minimum flow rate can cause damage.
- Handling, transportation and installation of this equipment should only be undertaken by trained personnel with proper use of lifting equipment. See "Uncrating and Lifting" Figures 1A and 1B for reference.
- Only water or other suitable HVAC media may be circulated through the use of these pumps. Circulation of hazardous, corrosive or flammable liquids by using these pumps is strictly prohibited.
- DO NOT turn on the electrical supply to the pump until all the plumbing connections and commissioning procedure have been completed.
- The pump must not be operated dry without fluid.
- Pipe systems must be installed in such a manner so there is no pipe strain and no piping loads are being transferred on pump flanges.
- Ensure that the motor installation instruction manual has been followed for determining the proper terminal connections so that correct pump rotation is obtained.

TRANSPORT AND STORAGE

Transport and Handling Requirements

The pump has been prepared for shipment at the factory in such a way as to minimize potential damage due to handling and transport. The equipment should not be subjected to excessive G-forces during the handling or transport. For large, heavy, rotating components, the manufacturer shall consider and adapt a means to restrict the movement of the rotating assembly to prevent damage to the bearings during transport. All such means shall be removed before installation.

Uncrating and Lifting

Pump is fastened securely to the crate before shipment. The pump should be removed from the crate carefully by using proper tools and equipment. After removing from crate make sure that all the components are in good condition and have been received as mentioned in the packing list. Report immediately to the concerned person/department if any component is missing or received in a damaged condition. Extreme care must be taken while handling the pump set. Slings and hooks should be used in such a manner, so that while lifting the pump is not exposed to stresses.

While lifting the pump or pump set (with or without driver) suitable lifting equipment of adequate capacity should be used. The unit should be unloaded and handled by lifting equally. Entire pump with base frame should be lifted at four or more points provided in base frame. At each nylon slings, chains, or wire rope to the hooks or clevises for lifting. Ensure that the lift angle of the slings, chains or wire rope is less than 45° from vertical.

▲ CAUTION Do not use lifting lugs on drivers or pumps to lift base plated units; these are only for the individual driver or pump.

Extra care must be taken when lifting base plated pump units without driver because of the unbalanced load that may exist due to the driver not being mounted on the base.

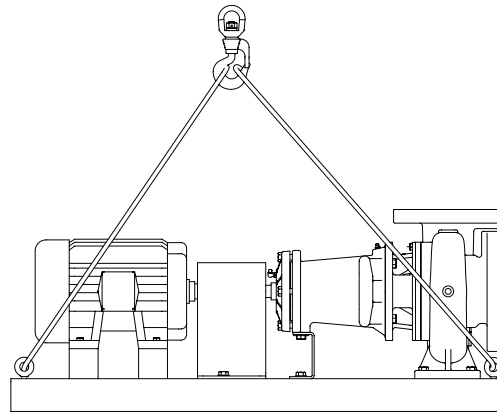

Figure 1A
Lifting of Pentair Aurora* 3804 pump assembly

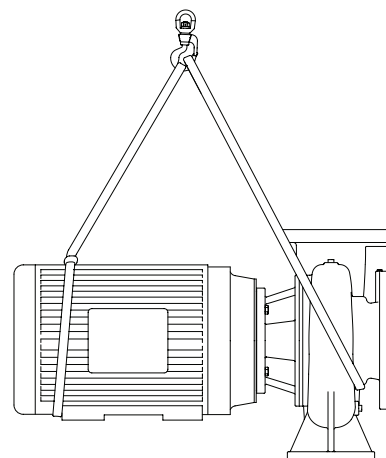

Figure 1B
Lifting of Pentair Aurora* 3801 pump assembly

Receipt, Inspection, and Damage Reporting

Upon receipt of the pump, immediately check for shortages of parts and damages. Prompt reporting to the carrier's agent, with notations made on the freight bill, may expedite resolution by the carrier.

Immediately upon receipt of the pump equipment, check carefully to see that all items have been received and are undamaged. Report any shortage or damage to the transport company handling the shipment and to the equipment manufacturer, noting the extent of damage or shortage on the freight bill and bill of lading. This should be done at once. Do not unpack any more than required to verify that the equipment is complete

PRODUCT DESCRIPTION

and undamaged unless installation is to be done immediately. Do not leave the pump unit or any accessories exposed to weather or construction hazards, which may cause damage to the equipment.

Unpacking

As stated above, do not unpack any more than required to verify that the equipment is complete and undamaged unless installation is to be done immediately. Check all packing material that is to be discarded to verify that no parts or instructions are being accidentally discarded as well. It is best to leave small parts in their shipping container until installation so they do not get misplaced. Make certain that accessories with a pump unit are clearly marked showing which pump unit they are to be used. Clean all parts of dirt, packing materials, and other foreign matter. Clean all non-coated machined surfaces. If the pump is to be installed immediately, then clean all coated machined surfaces too. Remove any rust spots found on the machined surfaces with a fine emery cloth. Clean all threaded connections and any accessory equipment.

Storage

The standard packaging is suitable for protection during shipment and during covered storage at the jobsite for a short period between installation and start-up. The preservatives applied at the factory have an effective life of two to three months from date of shipment, depending on the severity of the environment in which the equipment is stored.

Short Term Storage

The pump and equipment, as shipped, have adequate protection for short-term (up to three months) storage in a covered, dry, and ventilated location at the jobsite prior to installation.

- Dry pump internals and spray the liquid end with a water-displacement rust inhibitor.
- Apply a film of compatible lube oil over the water-displacement rust preventative.
- After the pump has been thoroughly drained, cover the pump suction and discharge flanges with full gasket material and blank off these openings with metal blank flanges and a minimum of four bolts. If mechanical seals have been used, then the annular opening between gland plate and shaft should be closed by a removable sealing ring supplied by the original equipment manufacturer to exclude airborne dust. Additionally, all connections in the seal cartridge must be plugged or sealed.
- All exposed painted surfaces should be dry, clean, and free of grease and other contaminants.
- The pump should be covered with a weather-resistant cover of waterproof paper or plastic to prohibit the build-up of dirt and dust accumulations.

Long Term Storage

All pumps are shop serviced and delivered in a ready to operate condition. If the pump after being delivered is not put into immediate operation, then proper care should be taken so that it operates without failure when put into service. The pump should be kept in a clean and dry area in a horizontal position. Ensure that the following precautions are taken for pumps being stored for more than three months.

- Pump surfaces which are machined and unpainted (e.g. flange ends, feet mounting etc.) and are easily subjected to corrosion must be protected by corrosion resistant coating.
- The pump shaft should be rotated once in a month to avoid locking of rotating assembly. This would also be helpful in uniform distribution of lubrication on bearings.

- Bearings must be lubricated with fresh lubricants when pump is being put into service after a long time.

Disposal of Packaging Materials

Most of the materials supplied in the pump unit are suitable for recycling. Please conserve our natural resources and recycle these materials.

PRODUCT DESCRIPTION

Configuration

Pumps are offered in two models.

- Pentair Aurora* 3801 close coupled
- Pentair Aurora 3804 frame mounted

Along with above mentioned models, pumps are also offered with following options required and mentioned by customer at the time of placing order.

- With or without flush line
- Oil lube bearings (frame mounted pumps only)
- Type 21 mechanical seal options (required for temperatures over 225°F or 107.2°C)

NSF Certifications Available

NSF50 Certified Pumps - New requirements

NSF50 certification is contingent upon the pump being paired with a motor having a permanent data plate that contains all the following information:

- Motor manufacturer's name and contact information (address, phone number, website, or prime supplier),
- Model number,
- Power rating (kilowatt or horsepower, or both),
- Speed,
- Voltage,
- Frequency,
- Phase,
- Service factor,
- Maximum load amps or full load amps (service factor amps),
- Serial number or date code or both,
- Frame size,
- Rated temperature rise or the insulation system class and ambient temperature rating,
- Time rating or duty rating, and
- Statement of thermal protection.

NSF61 Certified Pumps - No new requirements.

NSF372 Certified Pumps - No new requirements.

Parts

Refer to "Assembly Exploded View" Figures 45 and 46 on Pages 23-24 for listing various parts.

PUMP INSTALLATION

INSTALLATION

Pump Location

- Pentair Aurora* 3800 End Suction pump must be installed horizontally.
- The pump should be located as close to the liquid source as possible so that the suction line can be short and direct. See Figures 2 and 3 shown below.
- It should be located in a clean, open area, where it is easily accessible for inspection, disassembly and repair. Pumps installed in dark, dirty areas or in cramped locations are often neglected, which can result in premature failure of both the pump and the driver.
- Your pump should be located so that a hoist or crane can be used to move it without interference from piping. This factor is often overlooked in the advance planning stage.
- Install isolating valves on each side of pump so pump maintenance can be performed without draining the system.
- Special mounting requirements may be required if the pump is to be mounted near a noise or vibration sensitive area.
- The pump should be located in an area where moisture from condensation, can be adequately drained off. Moisture dripping on exposed metal or wood can cause rapid deterioration of the area. Also wet floor produces safety hazards.
- Adequate provisions should be made for electrical wiring to the pump motor. A switch and overload protection should be installed near the pump if conditions permit. The electrical conduit should be positioned in such a way as to preclude the possibility of moisture entering the conduit or the motor, and causing short circuits.
- The installation must be evaluated to ensure that the net positive suction head available (NPSHA) meets or exceeds the limits as stated below:
 - 2 ft for building services
 - 5 ft for municipal application
- Outdoor installation will normally provide all of the above mentioned conditions. However, it is recommended to provide a weather shelter for your pump.

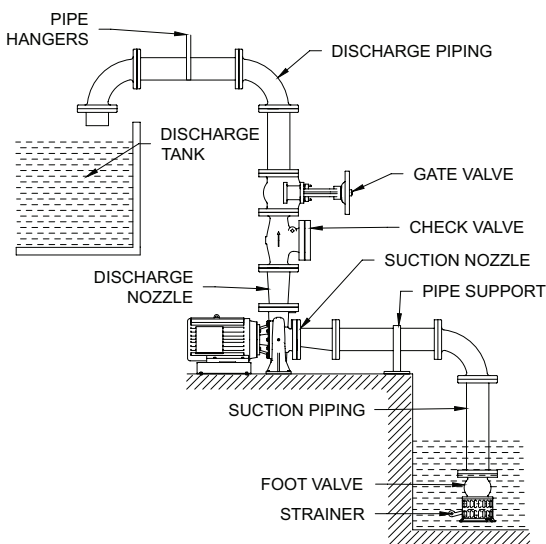

Figure 2
Recommended location (Short direct suction)

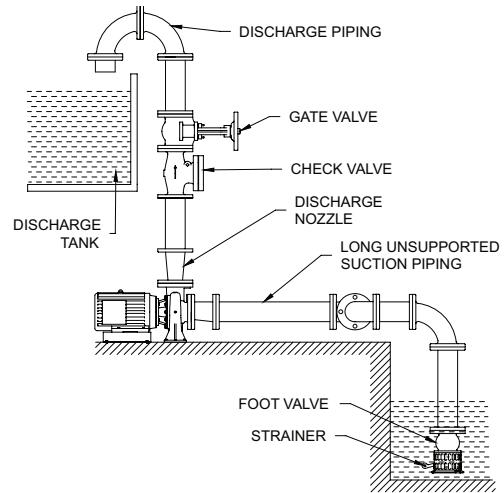

Figure 3
Unsatisfactory location (Long indirect suction with no support)

Foundation

The foundation for your pump must be sufficiently rigid to absorb any vibration and stress encountered during pump operation. The mass of the foundation should be sufficient; preferably five times that of the pumping equipment, to form a permanent and rigid support for the baseplate.

A raised foundation of concrete is preferable for most floor mounted pumps. The raised foundation assures a satisfactory base, protects against flooding, simplifies moisture drainage, and facilitates keeping the area clean.

- Your pump should be firmly bolted to the foundation, whether it is a raised concrete base, steelwork wall, or structural member. The mounting bolts or lag screws should be accurately located per the applicable Pentair Aurora dimension sheet.
- Bolt sizing is critical particularly on high-pressure pumps, to adequately restrain reaction forces generated from directional flow change, system transients, and sudden valve closure.

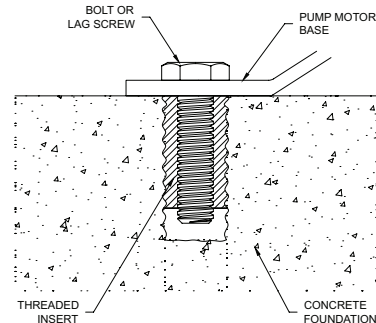

Figure 4
Typical close coupled pump mounting

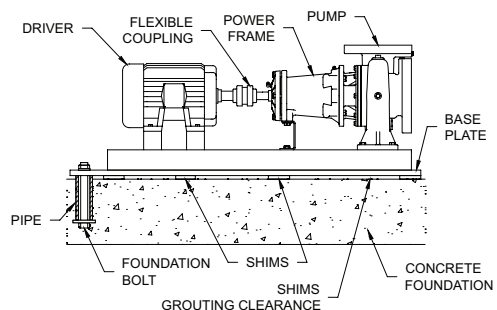

Figure 5
Typical flexible coupled pump mounting

PUMP INSTALLATION

- Lag screws or bolts screwed into threaded inserts in the concrete are recommended for mounting close coupled pumps, rather than studs set into concrete (Figure 4 on Page 6). This permits removal of the drive motor without disturbing the pump liquid end or the piping.
- If a large pump is to be mounted on steelwork or other structure, adequate support should be provided to prevent deflection of the structure which could produce excessive strain on the pump casing and piping.

Setting the Pump

- Check the mounting surfaces of the pump unit and the foundation to make sure they are clean and free of obstructions. Set the pump on the foundation, being careful not to damage the foundation bolts or studs if used.

- Tighten the nuts or bolts finger tight.

NOTICE: In close coupled pump assembly make sure the motor (driver) and pump casing are grounded.

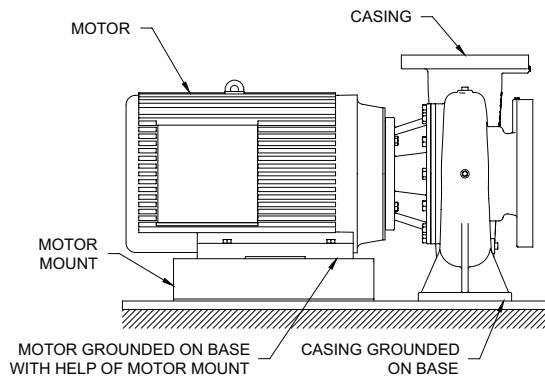

Figure 6
Setting a close coupled pump

Seismic Analysis

Please consult factory if the pump is to be installed in seismic zones.

BASE PLATE

Leveling The Pump

Pump unit leveling can be done using the suction and discharge nozzles or flanges as reference points. Insertion of a short piece of pipe in the threaded nozzles will facilitate use of a spirit level to determine whether or not the pump unit is leveled in all directions. See Figure 7 shown below.

A spirit level can also be used on the machined faces of the suction and discharge flanges (Figure 8).

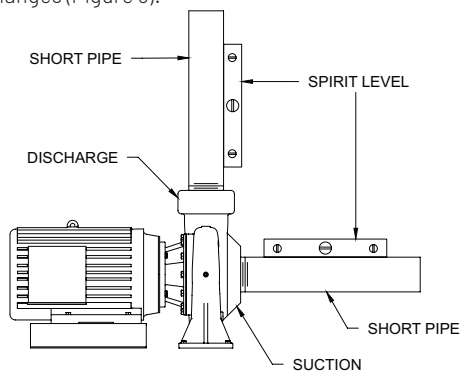

Figure 7
Leveling pump with spirit level and short lengths of pipe

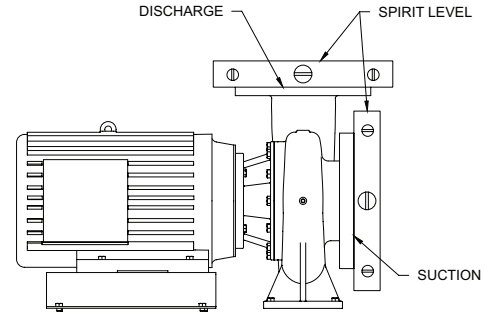

Figure 8

Leveling with spirit level on pump flanges

Leveling the pump can require enough shims to support the base plate near the foundation bolts and at any points of the base plate carrying a substantial weight load. The shims should be large enough to allow a gap of 3/4" to 1-1/2" between the base plate and foundation for grouting.

NOTICE: The pump base must be set level to avoid any mechanical difficulties with the pump or motor.

Pentair Aurora* 3804 pump was properly aligned, if supplied with a motor, at the factory. However, since the pump base is flexible, it may spring and twist during shipment. Do not pipe the pump until it is realigned. Realign the base after piping is completed and after the pump is grouted in and bolted down.

NOTICE: It may be necessary to readjust the alignment from time to time while the unit and foundation are new. Realignment may prevent premature bearing failure, excessive vibration or shaft failure.

Ensure that proper hydronic accessories such as pressure relief valves, thermal expansion tanks and flow/pressure control devices are installed in the system. Consult the responsible party for your system to ensure these devices are installed and of the proper size.

Grouting the Installation

Grouting the base plate prevents lateral movement of the base plate, and improves the vibration absorbing characteristics of the foundation by increasing its mass. A wooden dam should be constructed around the base plate to contain the grout while it is being poured. The dam can be built tight against the base plate, or slightly removed from it as desired. Refer to Figure 9 shown below.

The entire base plate should be completely filled with non-shrinkable type grout. The grout should be puddled frequently to remove any air bubbles from the grout.

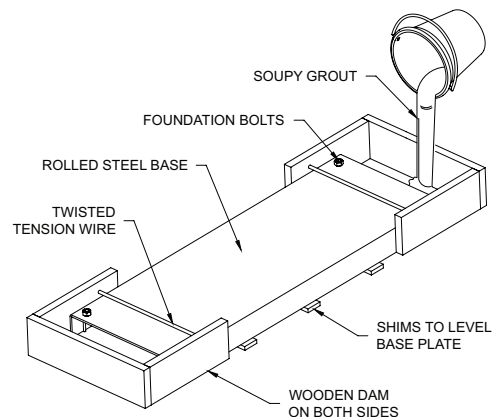

Figure 9

Grouting the base for frame mounted pumps

PUMP INSTALLATION

Piping and Connections

Inlet and outlet piping should be anchored, supported, and restrained near the pump to avoid application of forces and moments to the pump in excess. In calculating forces and moments, the weights of the pipe, internal thrust, contained fluid and insulation, as well as thermal expansion and contraction, should be considered. It is recommended that the first section of pipe be installed on the pump flange and then properly supported. Both the suction and discharge piping should be independently supported. The system piping should then be brought into alignment to the first section of pipe attached to the pump before completing the connections to the piping system.

To verify that there is no pipe strain and no piping loads being transmitted to the pump flanges, the flange connections are loosened and the alignment of the piping inspected. The piping to the pump inlet and outlet should be aligned to the pump flanges. The bolts should freely pass through flange with no binding. The alignment of the axis of the flanges should be within a tolerance of 1/2 the radial bolt clearance. Faces of the flanges should be in alignment so that the dimensions between the faces indicate that they are parallel and allow for the insertion of the gasket.

Suction Piping

The suction piping should be short, but no less than ten pipe diameters in length, and direct with as few elbows and fittings as possible to keep head loss, from friction, at a minimum. However, the suction pipe should provide a minimum uninterrupted length, equal to ten pipe diameters, to the pump suction flange. A horizontal suction line should have a gradual rise to the pump, and pass under any interfering piping. See Figure 10 shown below.

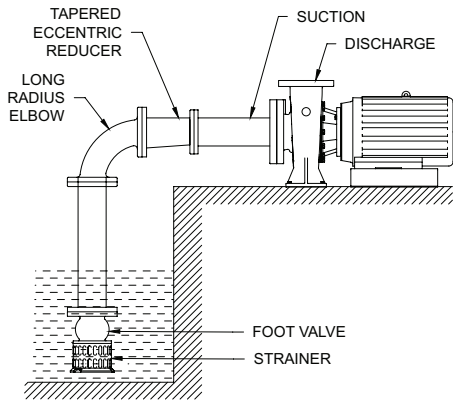

Figure 10

Recommended suction lift piping (Short and direct)

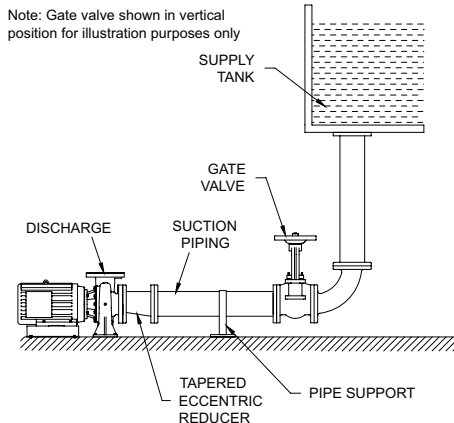

Figure 11

Recommended flooded suction piping (Short and direct)

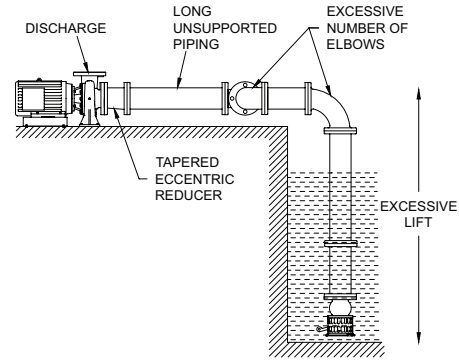

Figure 12

Unsatisfactory suction lift piping (Long and indirect with no support)

Pipe

The suction pipe diameter should be at least the same diameter as the suction nozzle on the pump, and preferably larger. Use of a smaller diameter pipe will result in loss of head due to friction. All joints must be tight to maintain prime on the pump.

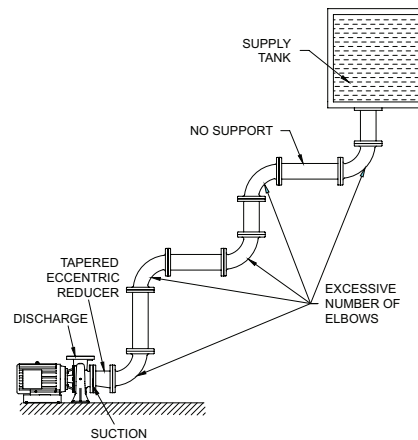

Figure 13

Unsatisfactory flooded suction piping (Long and indirect with no support)

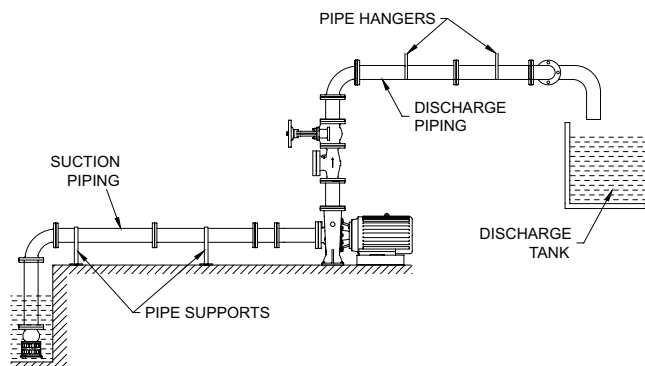

Figure 14

Supporting piping

Elbows

Long radius elbows should be used in place of standard elbows wherever possible, because of their superior flow characteristics. For instance, head loss in a standard four inch elbow is equivalent to the head loss in a piece of pipe 11 feet long, while the head loss in a long radius elbow is approximately half as much. Elbows should not be used at the suction

PUMP INSTALLATION

nozzle, but if it is unavoidable, they should be installed in a vertical position. Elbows installed in any position at the suction nozzle have a tendency to distribute the liquid unevenly in the impeller chamber, causing a reduction in capacity, and creating an undesirable thrust condition. See Figures 15, 16A, and 16B shown below.

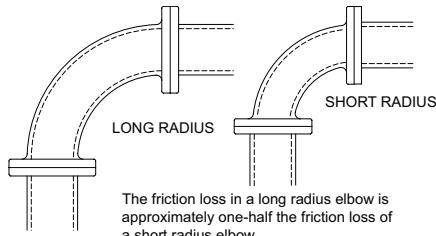

Figure 15
Long versus short radius elbows

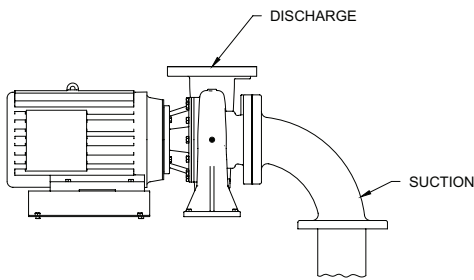

Figure 16A
Correct elbow installation on suction nozzle

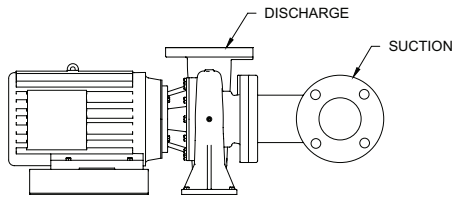

Figure 16B
Incorrect elbow installation on suction nozzle

Reducers

Eccentric reducers should be installed directly at the suction nozzle, with the taper at the bottom to prevent air pockets from forming. Straight taper reducers should never be used in a horizontal suction line because of the air pocket that is formed at the leg of the reducer and the pipe. See Figures 17A, 17B, and 18 shown below.

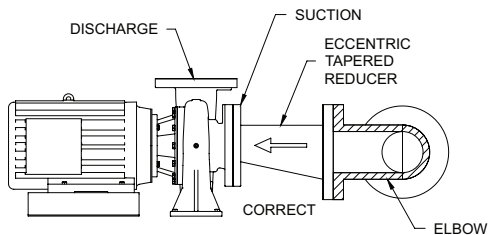

Figure 17A
Correct Installation of eccentric tapered reducers

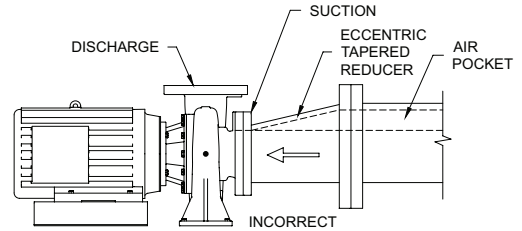
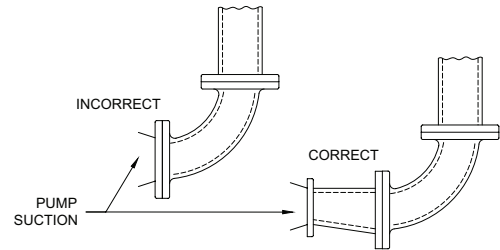

Figure 17B
Incorrect Installation of eccentric tapered reducers



Spacer between suction and elbow permits equal flow of water to each side of double suction impeller, prevents excessive thrust and resulting wear on bearings, etc.

Figure 18
Reducer between elbow and pump suction nozzle

Discharge Piping

Discharge piping should also be short and direct as possible, with few elbows and fittings, to reduce head loss from friction. See Figures 19 and 20 shown below.

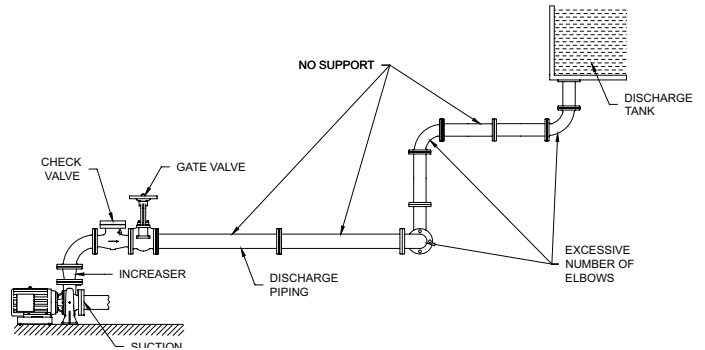

Figure 19
Unsatisfactory discharge piping
(Long with excessive elbows and joints)

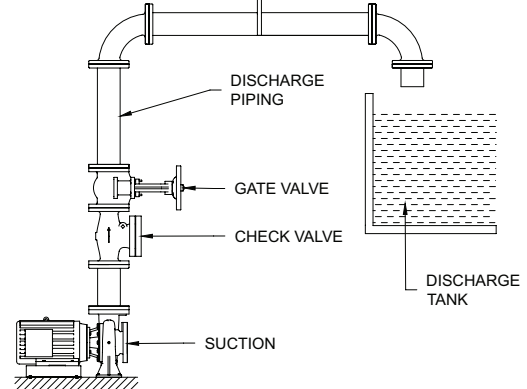

Figure 20
Recommended discharge piping
(Short and direct)

PUMP INSTALLATION

Pipe

The discharge pipe diameter should be the same as, or larger than, the discharge nozzle diameter. The size of discharge pipe to be used is dependent upon the application. The recommended pipe diameter can be obtained from your nearest Pentair Aurora* authorized distributor or Customer Service.

Reducers and Increases

An increaser should be installed at the discharge nozzle if larger diameter discharge piping is used. Straight taper increasers and/or reducers are satisfactory in discharge piping, because air pockets on the discharge side do not affect pump efficiency. See Figure 21 below.

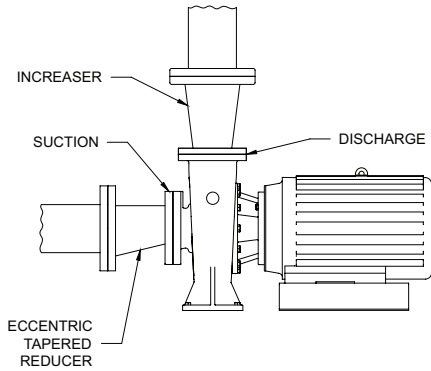

Figure 21
Reducer and increaser installation

Valves

Valves are an important part of your installation. They facilitate priming of the pump, and control the volume of the pumped liquid.

Foot Valves

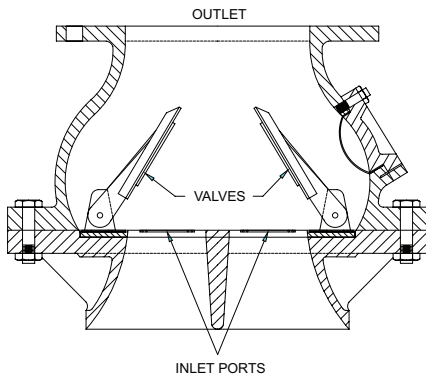

Figure 22
Foot valve

Suction Lift: In suction lift applications where the suction lift is low, a foot valve can be installed to maintain the prime of the pump. A foot valve is essentially a check valve, allowing flow in one direction only, towards the pump. When the pump is shut down, the pressure of the liquid returning to the well causes the valve to close, retaining the liquid in the suction line.

A slow closing check valve should be installed when the static discharge head is high. A foot valve should not be used under these conditions, as failure of the driver would allow the water to rush back rapidly thus causing a heavy water hammer.

Foot valves, when used, should be the flat type rather than multiple spring type. The valve should have a large inlet area, because the

friction loss in the foot valve is high. Install check and foot valve as indicated by arrow to ensure proper installation.

Flooded Suction: When the liquid source is above the pump centerline, a flooded suction condition exists and a gate valve is required to shut off the liquid supply for pump inspection and maintenance. The gate valve should be installed with the stem in a horizontal or downward position to prevent formation of an air pocket in the valve.

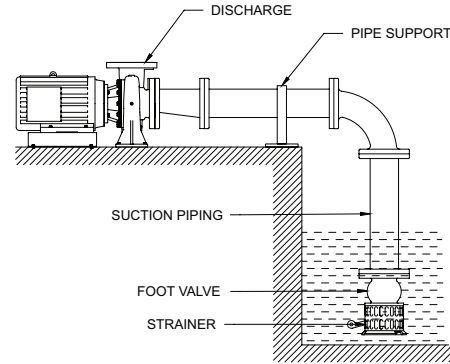

Figure 23
Foot valve installed with screen

Discharge Valves

The discharge piping should include a check valve and a gate valve. The check valve should be located between the gate valve and the pump. If an increaser is used in the discharge piping, the increaser should be installed between the pump nozzle and the check valve. The check valve protects against a reverse flow of the liquid if the driver fails. See Figure 24 shown below.

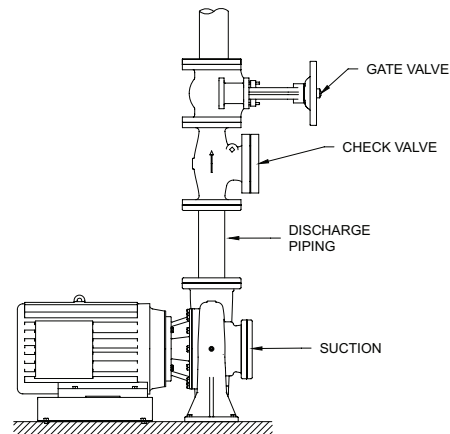

Figure 24
Gate Valve and Check Valve

PUMP INSTALLATION

Air Vent Valves

Vent valves are installed at the high points in the pump casing to allow air or vapor to escape. These valves are used to release trapped air from the pump casing during priming and when pump becomes air bound. See Figure 25 shown below.

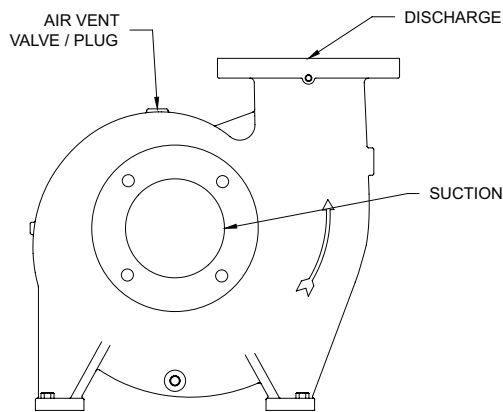

Figure 25
Air vent valve or plug

Expansion Joints

Expansion joints are used primarily to prevent transmission of piping strain, caused by thermal expansion and contraction, piping misalignment, pressure changes, or other causes, to the pump casing. They are also used to suppress any noise that may be transmitted through the piping. It is recommended that the flexible metal type of expansion joint be used because rubber expansion joints, have a tendency to deteriorate, making frequent replacement necessary.

If an expansion joint is used, an anchor or a restraining device should be installed between the joint and the pump to prevent objectionable forces from being transmitted to the pump. If an anchor is not installed at this point, a force equal to the area of the expansion joint times the pressure in the pipe is developed and transmitted to the pump. This force may exceed the allowable flange loading and could result in damage to the pump or piping. See Figures 26 and 27 shown below.

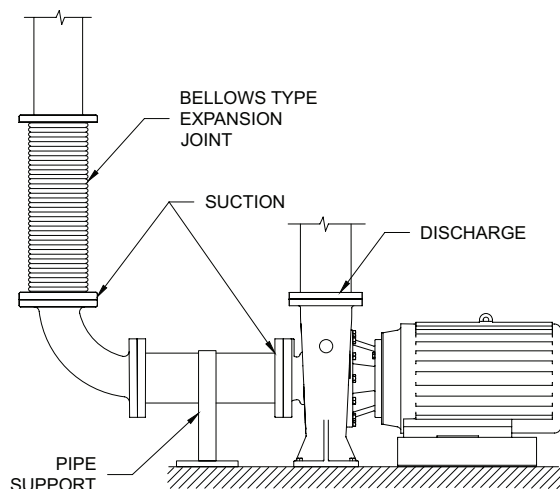

Figure 26
Expansion joint in suction line

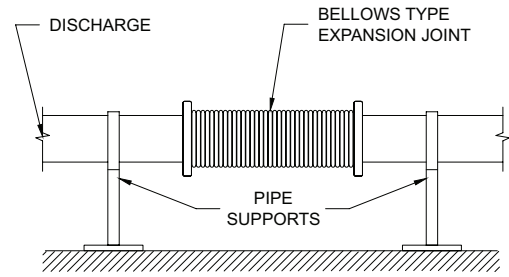

Figure 27
Expansion joint in discharge piping

Strainers and Screens

It is important to remove foreign matter that can clog the pump and impair its capacity, or stop it completely. Small particles such as sand, dirt, scale from inside pipe and other extraneous materials can get into the close clearance parts of the pump and cause considerable damage to the parts.

Strainers should be selected to have a total area of holes equal to at least four times the suction pipe area.

In applications where stick, twigs, leaves and other large debris are present, a larger outside screen should be placed around the suction inlet to prevent choking of the strainer. This screen should have sufficient openings so that flow velocity does not exceed two feet per second.

ALIGNMENT

General Alignment

Pumps and drivers received from the factory with both machines mounted on a common baseplate are aligned or checked for alignment before shipment. All baseplates are flexible to some extent and, therefore, must not be relied on to maintain the factory alignment. Realignment is necessary after the complete unit has been leveled, the grout has set, foundation bolts have been tightened and the piping has filled with fluid. The alignment must be rechecked after the unit is piped and rechecked periodically.

SHAFT/COUPLING ALIGNMENT

Initial Alignment of Flexible Coupling

A flexible coupling is used to compensate for minor misalignment of the pump and driver shaft and is limited to misalignment due to minor temperature changes.

The pump and driver were accurately aligned at the factory. However, alignment cannot be maintained during shipping and handling. Therefore it will be necessary for you to realign the pump and driver. Flexible couplings are not universal joints. They should not be used to compensate for misalignment of the pump and motor shafts. Their function is to transmit power from the driver to the pump while compensating for thermal expansion and shaft end movement. The coupling faces should be far enough apart so that they do not make contact when the motor shaft is forced to the limit of the bearing clearance toward the pump shaft.

In order to properly align the coupling, you will need a taper gauge or set of feeler gauges, and a straight edge.

There are two types of misalignment encountered with flexible couplings: angular misalignment, in which the shafts are not parallel, and parallel misalignment where the shafts are parallel but not on the same axis.

PUMP INSTALLATION

To check angular alignment, insert a feeler gauge or taper gauge at any four places 90° apart around the coupling halves. Insert shims under the driver feet until the same reading is obtained at all four check points. The pump and driver will then be in angular alignment.

To check parallel alignment, a straight edge should be held against the edges of the coupling halves at any four places 90° apart around the coupling. The straight edge should be parallel to the pump and driver shafts at all times. Insert shims until the straight edge lies flat against both coupling halves at all four checkpoints. The pump and driver will then be in proper parallel alignment. For more detailed alignment information consult the coupling manufacturer's installation instructions. Refer to Figure 28 shown below.

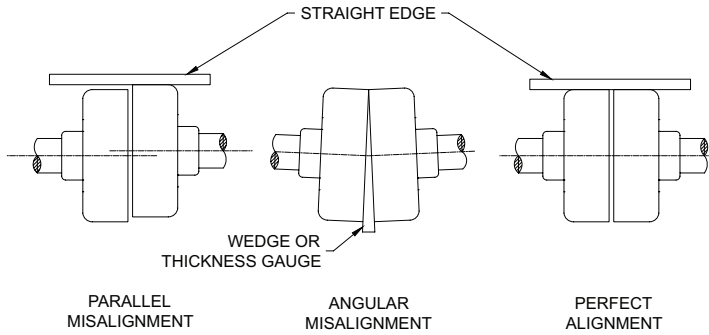

Figure 28
Flexible coupling alignment piping

For Fine Alignment, 3500 RPM Operation, For All Other Coupler Types

A dial indicator should be used when greater alignment accuracy is required. Use the following alignment tolerances unless specified otherwise by the coupling manufacturer. On sleeve type couplings make sure there is at least 1/8" end clearance between the sleeve and the two coupling halves.

To check angular misalignments, mount the dial indicator base to the coupling half, and position the dial indicator button on the front or rear face of the opposite coupling half. Set the dial to zero, rotate both coupling halves together, making sure the indicator button always indicates off the same spot. Misalignment values within 0.004 inches TIR per inch of coupler radius is permissible.

To check parallel misalignment, mount the dial indicator base to one coupling half, or shaft and position the dial indicator button on the outside diameter of the opposite coupling half. Set the dial to zero. Rotate both coupling halves together, making sure the indicator button always indicates off the same spot. Misalignment within 0.004 inches TIR is permissible.

Pipe Alignment

Proper piping alignment is essential before connection is made. Piping alignment should never be achieved by force, as this could produce strain on the piping and the pump casing. Proper supports should be installed for the piping to keep its weight off the pump casing.

When flange bolts are used, line up the piping first, then loosely install flange bolts. Check the piping alignment, and tighten the flange bolts until all bolts are tightened securely. See Figure 29 shown below.

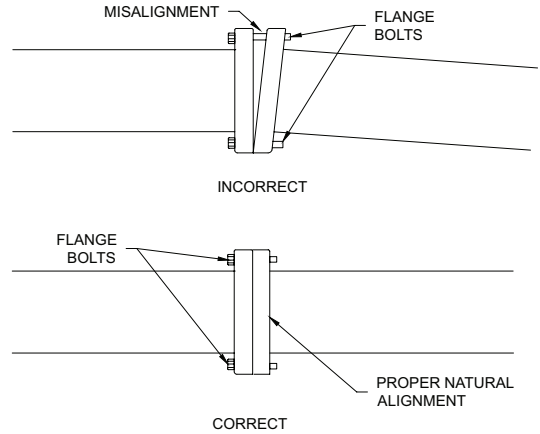

Figure 29
Pipe alignment

Air in Piping

One of the most common conditions affecting pump efficiency is the formation of air pockets in the suction line. The air pockets are a result of high points and improper installation of elbows, reducers, and valves in the suction piping. See Figures 30 and 31 shown below and on next page.

The pump seal depend on the liquid being pumped for lubrication with resultant damage to them.

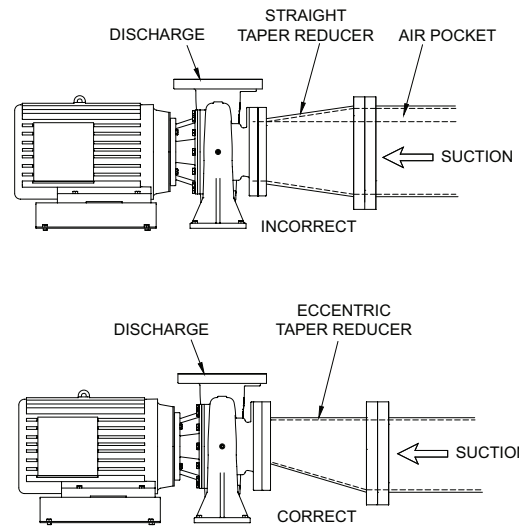

Figure 30
Air pocket in reducer

PUMP OPERATION

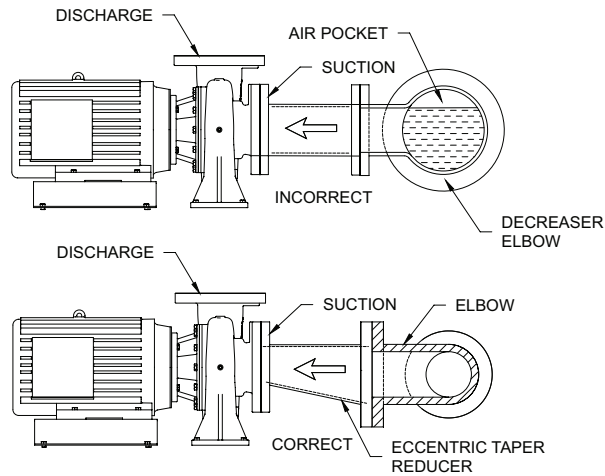

Figure 31
Air pocket in elbow

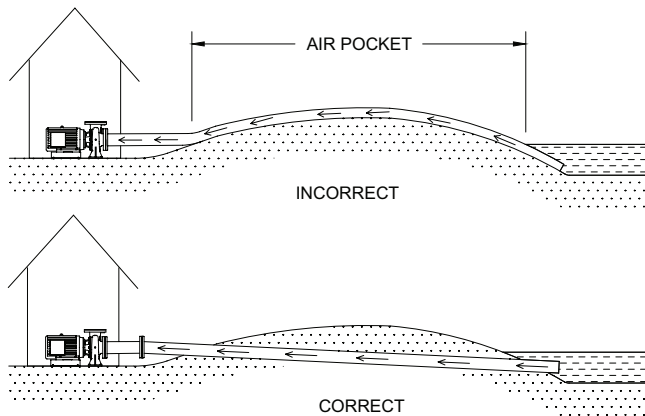

Figure 32
Air pocket in horizontal suction piping

In suction lift applications, the suction pipe in the liquid well must be sufficiently submerged to prevent exposure of the end of the pipe when the well is at its minimum level and to prevent vortex action (whirlpool effect) of the liquid at the suction pipe, which will draw air into the pipe. Also, care should be taken to keep the suction pipe located away from the well inlet since the incoming liquid may be carrying air bubbles. Another cause of air in the liquid is dropping of the liquid from too high a point into the well. See Figure 32 shown above.

Electrical Wiring

Normally, your pump will be supplied with an attached drive motor. The motor should be wired in accordance with the wiring diagram found on the motor nameplate. Be sure the voltage, frequency, and phase of your power supply corresponds with the nameplate data. It is recommended to provide a separate switch and overload protection for your pump motor to protect against power failure in some other area. Conversely, if the pump motor develops electrical problems, it will be isolated from other equipment.

Notice: PRESTARTING INSTRUCTION: The coupling halves should be connected. Prior to connection, however, the drive motor should be started to make sure the direction of rotation is the same as the direction indicated by the arrow on the pump casing.

COMMISSIONING, START-UP, OPERATION, AND SHUTDOWN

Lubrication

In dry locations, each bearing will need lubrication at least after every 4,000 hours of running time or 6 to 12 months, whichever is more frequent. In wet locations (exposed to dripping water, to the weather or to heavy condensation found in unheated or poorly ventilated underground locations) every 2,000 hours or every 3 to 6 months, whichever is more frequent. Applicable to 3804 series pumps.

- Use Chevron® SRI Grease NLGI grade 2.

CAUTION Before running the driver, either separately or connected to the pump, check lubrication and cooling requirements.

CAUTION Proper lubrication is critical for trouble-free, long-term operation of the equipment. Lubrication methods and frequency vary with bearing type, application, environment, and the unique operating characteristics of the individual piece of equipment. Ensure lubrication is present and lubrication systems are connected and operational per instructions.

Rotation

Pump rotation is clockwise when viewed from the back of the motor. An arrow is also located on the pump casing to show the direction of rotation.

It is absolutely essential that the rotation of the motor be checked before connecting the shaft coupling. Incorrect rotation of the pump, for even a short time, can dislodge and damage the impeller, casing, shaft, and shaft seal.

Guarding

All guards must be in place and secure per the instructions prior to start-up.

WARNING Guards must not be removed while the pump is operational. Always follow lock out – tag out procedures when working on equipment that may turn on.

START-UP CONSIDERATIONS

System Flushing

When the pump is installed in the completed piping system, it is recommended that the system be flushed to remove debris such as stubs of welding rod, welding slag, and loose scale. The pump manufacturer should be consulted as to the suitability of any chemical flush additives added to the system.

Priming and Filling

The pump should not run unless it is completely filled with liquid as there is danger of damaging some of the pump components. This includes short runs for rotation verification. The pump will not operate satisfactorily until it is primed. All air must be expelled from the suction piping and pump casing, and replaced by the liquid to be pumped. There are several methods of priming pumps. The one you select will depend on your specific requirements.

Flooded Suction Priming

This method of priming a pump is relatively simple. The liquid source is located above the pump, and all that is necessary to prime the pump is to open the air vent valve or plug in the pump casing, and to crack the gate valve in the suction line. The suction line and pump should be filled

PUMP OPERATION

slowly until a steady stream of liquid is observed flowing from the air vent. After your pump is operating, it is recommended that the air vent valve or plug be opened again to ensure that all air has been expelled from the pump casing. See Figure 33 on shown below.

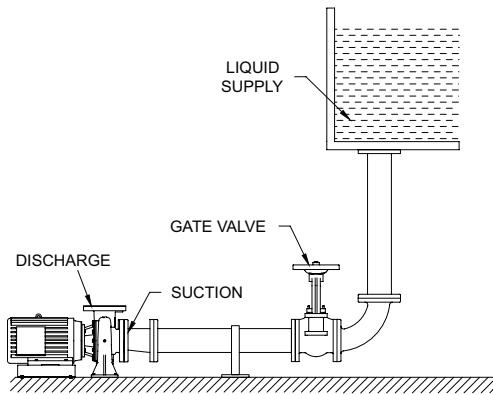

Figure 33
Flooded suction priming

Foot Valve Priming

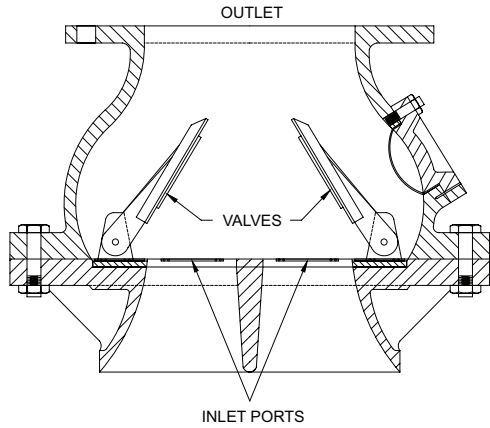

Figure 34
Foot valve cutaway

A foot valve can be used for priming on suction lift applications. The foot valve located at the bottom end or foot of the suction piping, functions as a check valve which allows flow in one direction only toward the pump.

Initial priming is accomplished by completely filling the suction piping and pump casing with the liquid to be pumped. This can be done by removing the air vent valve or plug at the top of the pump casing, and inserting a pipe nipple in the orifice with an appropriate increaser to accommodate a hose connection.

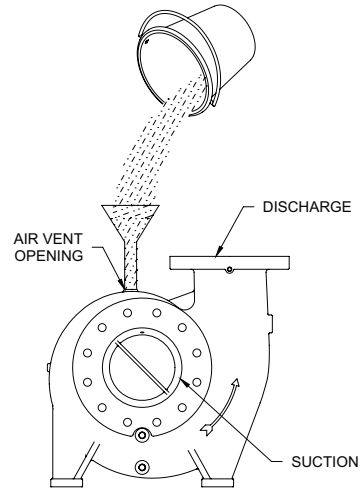

Figure 35
Priming by hand

A priming line can also be inserted in the discharge piping between the check valve and the pump, or the priming can be done with a bucket and funnel. Refer to Figure 35 shown above. It is important to completely fill the suction pipe and pump casing with liquid. When the pump is started, the vacuum created by pumping the priming fluid, combined with atmospheric pressure in the liquid well, forces liquid into the suction piping, thus opening the valve and keeping it open until the pump is shut down. When the pump is shut down, the liquid being pumped reverses its flow causing the valve to close. The liquid is now trapped in the suction piping and pump casing, thus maintaining a prime on the pump.

Vacuum Priming

Vacuum priming consists of removing air from the pump casing and suction piping, and drawing liquid into them by means of a vacuum creating device. The types of vacuum equipment range from a simple hand pump to complex central priming systems. Your specific priming requirements will govern what type of vacuum primer you use.

Air Ejector

One type of vacuum primer is the air ejector. If liquid under pressure or steam is available, an ejector can be used. The ejector is connected to the air vent orifice. A stream of the ejecting medium is passed through the ejector creating a vacuum in the ejector, and drawing air from the pump casing and suction piping. When liquid flows steadily from the ejector discharge pipe, the pump is primed. See Figure 36 shown below.

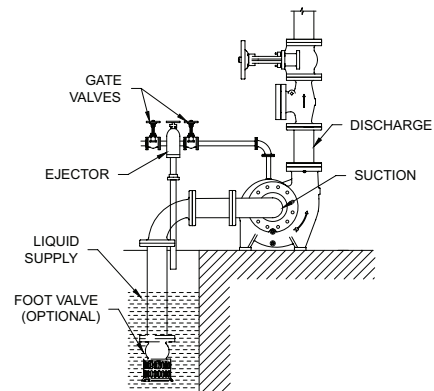

Figure 36
Priming by ejector

PUMP OPERATION

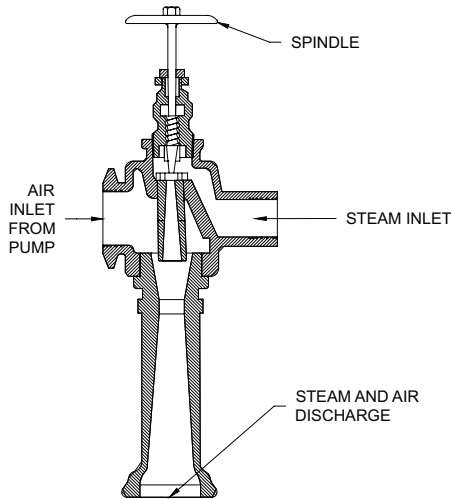

Figure 37
Ejector cutaway

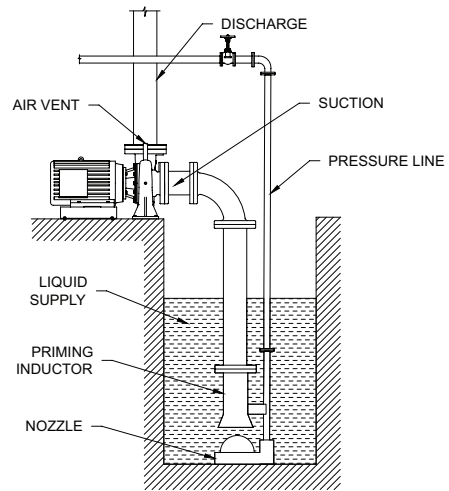

Figure 39
Inductor priming

Vacuum Pumps

Rotary or reciprocating pumps are frequently used as vacuum pumps. They fall into two categories, wet-vacuum and dry-vacuum. The principle of operation is essentially the same, however, the dry-vacuum pump cannot accommodate a liquid and air mixture, while the wet-vacuum pump can accommodate liquid, air, or a combination of both.

Vacuum pumps can be installed as part of a central priming system servicing many pumps, as an automatic priming system, or as a manually controlled independently driven pump.

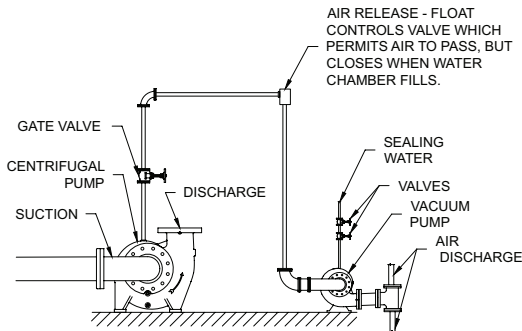

Figure 38
Vacuum pump priming

The suction piping of the vacuum pump is connected to the air vent orifice on the pump to be primed. The vacuum produced by the vacuum pump removes air from the turbine pump suction piping and casing, and draws liquid from the liquid well into the turbine pump. Dry-vacuum pumps must be installed so that no liquid is taken into the air pump. Installation of a water trap or use of a vacuum tank is recommended for dry-vacuum pumps. Refer to Figure 38 shown above.

Inductor Priming

On suction lift applications it may be desirable to prime your pump with a priming inductor. This type of primer is comprised of a liquid nozzle and an inductor at the foot end of the suction piping. The nozzle and inductor are connected to a high pressure liquid supply such as a city water service. The pump is primed by opening the valve in the pressure line. This will allow the liquid to flow through the nozzle and into the inductor. The velocity of the high pressure liquid drives the liquid into the suction piping and up to the pump, thus completing the priming operation. Refer to Figure 39.

SHAFT SEALING SETTINGS AND ADJUSTMENTS

Mechanical Seals

A mechanical seal consists of a rotating element and a stationary element. The sealing faces are highly lapped surfaces on materials selected for their low coefficient of friction and their resistance to corrosion by the liquid being pumped. The faces run with a very thin film of liquid between them. In addition, there must be a means of loading the seal. This is accomplished either with a spring (or springs) or with an elastomeric or metallic flexible member.

Mechanical seals are made in a wide variety of designs; therefore the instructions for the specific seal must be carefully studied and followed. A mechanical seal is a precision device and must be treated accordingly. Mechanical seals normally require no adjustment during operation. Except for slight initial leakage, the seal should operate with negligible leakage.

CAUTION Mechanical seals should not run dry unless allowed by the manufacturer. Seals require a continuous supply of flush and/or cooling fluid.

START-UP, OPERATION, AND SHUTDOWN

Valve Setting at Start-up

Position of Discharge Gate Valve When Starting

The discharge gate valve should be partially closed when a high or medium head centrifugal pump is started, because this type of pump requires much less power with the gate valve closed, than when it is operated at rated capacity and head with the discharge gate valve open. As soon as the pump is up to operating speed, the discharge gate valve should be opened to the desired position.

Position of Suction Piping Gate Valve When Starting

In flooded suction applications, the gate valve is opened at the time the pump is being primed, and will remain open for starting and operation.

CAUTION The pump should not be operated with the inlet or outlet valves closed. The operation of a pump with the inlet valve closed may cause serious damage and should not be attempted. Operation with both inlet and outlet valves closed for even brief periods of time is an unacceptable and dangerous practice.

PUMP MAINTENANCE AND SERVICE

Operation

The following points must be ensured before starting the pump:

1. The current supply agrees with the voltage and frequency on the motor nameplate.
2. The motor is wired for correct voltage.
3. The thermal overload relays are correct size and set for operation.
4. The pump is fully primed. Flood the casing and seal area with liquid to release the air out of pump through flush line and air vent valve near discharge flange. Priming must be continued until air is completely removed. This is indicated by continuous flow of liquid through flush line and air vent. Disconnect power to the motor and lock-out / tag-out the power source prior to rotating the shaft by hand.
 - a. Failure to flood the seal area with water may cause seal failure due to lack of lubrication.
5. Jog the motor to check that the motor rotates clockwise, as indicated by the arrow on the pump casing.
6. Coupling guard must be in its appropriate position on account of human safety.

Starting Up

1. Start the pump with the discharge valve slightly open and verify that the pump is operating smoothly and is not rubbing.
2. Start opening the discharge valve gradually.

Notice: Do not run the pump for extended period with discharge valve closed, so as to avoid overheating and potential damaging loads.
3. If the pump is equipped with a circulation relief valve, such valve prevents overheating when the pump is operating at reduced capacity.
4. Stop the pump immediately if any of the following situations arise:
 - a. No/insufficient liquid.
 - b. Inadequate discharge pressure.
 - c. Loss of suction pressure.
 - d. High power consumption.
 - e. Noisy operation and/or high vibration after discharge valve is in an open position.
Check the manual for troubleshooting the cause. See Pages 21 - 22.

Shut Down

It is recommended to close the discharge valve before stopping the pump to avoid any water hammer effect. However, this practice is not mandatory and pump may be stopped with discharge valve open in case an emergency.

Preferred shutdown sequence is as follows:

1. Preferably close the discharge valve first.
2. Then turn off the motor.
3. Now, close the suction line valve.
4. Drain the pump liquid completely, if pump to be kept nonoperational for longer period or if there is danger of freezing.
5. If it is necessary for the pump to maintain its prime while it is shutdown, it is recommended to install either a foot valve or a check valve in the suction piping.

MAINTENANCE AND SERVICE

Schedule

Preventive maintenance and routine check-ups may prevent the pump from major failures. An inspection & maintenance log should be kept and the inspector is to immediately report any problems. Pump should be checked on regular basis for any unusual noise, vibrations and abnormal rise of temperature. If equipped with a sight flow indicator, check it from time to time for fluid flow and if no flow is observed, replace the filter or check the separator. A suggested guide for preventive maintenance for normal application is given below in Table 1:

Table 1

Guide for preventive maintenance

ITEMS	ACTION REQUIRED	FREQUENCY
Vibration	Check for change in vibration levels	Refer to ANSI/HI 9.6.5 Condition Monitoring
Bolting	Check for proper bolt torque	Annually
Mechanical Seals	Monitor seal leakage	Refer to ANSI/HI 9.6.5 Condition Monitoring
Pump/Motor Alignment	Check for change in alignment	Annually
Surface Inspection	Check for coating integrity or signs of corrosion	Exterior components: Quarterly Interior components: Annually
Wear and running clearance	Inspect and measure	Annually or as determined by service condition when performance decreases are noted or as recommended
No flow in sight flow indicator (if installed)	Replace filter, Inspect separator	Daily
Controls and accessories	Inspect for damage, proper function and condition	Annually
General site conditions	Inspect for damage, proper function and condition	150 hours of operation as necessary

PUMP MAINTENANCE AND SERVICE

Cold Weather Maintenance

When handling water or other liquids that may freeze at low temperatures, care should be taken to prevent the pump from freezing during cold weather when the pump is not in operation. It may be necessary to drain the pump casing during shutdown periods by removing the bottom drain plug.

Mechanical Seal Maintenance

The mechanical seal require flushing which is flushed from discharge of the pump through a flush line. A throttle bush isolates the mechanical seal from the liquid in the pump. Since mechanical seals need a film of liquid between the sealing faces, pump must not be run unless properly filled with liquid for intended operation.

A 'weep' sound may be heard from mechanical seals at start-up. The pump should run for approximately 8-10 hours, which is the break-in period for seal. During this operation the mechanical seal would 'seat' properly.

Pentair Aurora* 3800 pumps are supplied with type 21 mechanical seal.

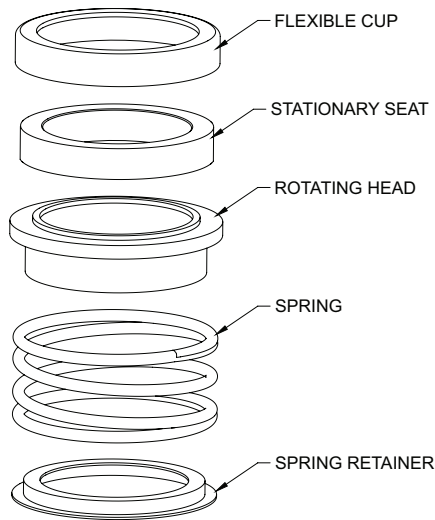

Figure 40
Mechanical Seal (type 21)

Recommended Spare Part List

Although all the components could be procured by the customer at short interval, to reduce downtime the below mentioned components should be kept handy in case the pump is to be shut down for maintenance. The components are:

- Mechanical seal
- Wear rings
- Gaskets, O-rings, seals

Notice: Refer to Table 2 before ordering seal kit corresponding to power frame numbers in case of Pentair Aurora 3804 pumps.

Table 2

Pentair Aurora 3804 pumps seal kit selection matrix

IMPELLER SIZE ¹	POWER FRAME NO.	POWER FRAME PART NO.	SEAL KIT NO.
7" PUMPS	1	3550006644	4761251644
	2	3550008644	4761252644
	3	3550009644	4761252644
	21A	NA	NA
ALL 9.5" PUMPS EXCEPT 6x8x9.5	1	3550006644	4761254644
	2	3550008644	4761255644
	3	3550009644	4761255644
	21A	NA	NA
6x8x9.5	1	NA	NA
	2	3550008644	4761256644
	3	3550009644	4761256644
	21A	NA	NA
11" PUMPS	1	3550006644	4761257644
	2	3550008644	4761258644
	3	3550009644	4761258644
	21A	3550300644	4761260644
1.5x2x12	1	3550006644	4761261644
13.5" PUMPS	1	NA	NA
	2	3550008644	4761263644
	3	3550009644	4761263644
	21A	3550300644	4761264644

¹Last digit of pump model denotes impeller size. E.g., 2x2.5x7, here 7" is the impeller size

Consumables

Following items are of regular use during preventive and accidental maintenance and must be kept in stock by the customer.

- Lubricants
- Cleaning materials
- Touch up coating

Tools and Fixtures

Pump assembly and disassembly can be performed by using standard hand tools available in market. For quick reference, tools required for disassembly of various pump components are mentioned below in Table 3 on the next page.

PUMP MAINTENANCE AND SERVICE

Table 3

Quick reference for tools and fixtures

ITEM NO.	MOTOR FRAME	PUMPS	WRENCH SIZE AND TYPE
#4 & #4A	ALL	ALL	9/16" wrench
#5	ALL	7"	9/16" wrench
		9.5", 11"	3/4" wrench
		13.5"	1-1/2" wrench
#5B	143-184	9.5", 11", 12", 13.5"	9/16" wrench
	213-215	9.5", 11", 12", 13.5"	
	254-256	9.5", 11", 13.5"	
	284-326	9.5", 11", 13.5"	
	364-405	9.5"	3/4" wrench
	444-449	9.5"	
#9	143-215	7", 9.5", 11", 13.5"	9/16" socket wrench
	254-326	7", 9.5", 11", 13.5"	3/4" socket wrench
	364-449		
#32	143-184	7", 9.5"	9/16" wrench
	213-215	7", 9.5", 11", 13.5"	3/4" wrench
	254-256		
	284-326		
	364-405	7", 9.5", 11", 13.5"	1-1/2" wrench
	444-449 TCZ		

In addition to the above mentioned tools some additional equipment & fixtures may be required which are mentioned below:

- Lifting devices (crane, hoist, lifting chains or straps)
- Impeller puller (to remove pressed-on impeller from shaft)
- Torch (to heat parts to aid in removal)
- Die grinder (to cut out wear rings or shaft sleeves, if needed)
- Work table or fixture for holding pump
- Measuring equipment (feeler gauges, dial indicator, etc.)
- Bearing puller (to remove pressed on bearings from shaft)
- Hot oil bath (or method to heat bearings and coupling hubs for installation)

Fastener Torque and Sequence

Proper tightening of bolting is very important. Torque values will vary depending on the size and grade of bolting used. Torque values for coupling bolts and grub screws and sequence of their tightening are mentioned in the following section for replacement procedure of mechanical seals. Tightening torques for common bolt diameter can be found in Table 4 below.

Table 4

Cap screw torque for common bolt diameters

CAPSCREW TYPE	HEAD MARKING	IN-POUNDS				FOOT-POUNDS		
		1/4"	5/16"	3/8"	7/16"	1/2"	5/8"	3/4"
SAE GRADE 5		85	180	27	43	65	130	230

REPAIRS

Notice: READ AND UNDERSTAND ALL SAFETY WARNINGS AT THE BEGINNING OF THE MANUAL BEFORE BEGINNING INSTALLATION OR ANY REPAIR WORK

This repairs section is broken into two major parts. The first part covers the dismantling of the mechanical seal, power frame disassembly and complete pump disassembly. The second part covers installation of mechanical seal, power frame reassembly and complete pump assembly. Refer to the exploded pump diagram (Figures 45 and 46 on Pages 23-24) for item numbers.

Complete Pump Disassembly - Pentair Aurora* Model 3804/3801

⚠ WARNING Sudden Start-up Hazard. Disconnect and lock out power source before servicing. Failure to follow these instructions could result in serious personal injury, death or property damage.

1. Ensure the electrical power is locked out, the system pressure has been lowered and temperature of the unit is at a safe level.
2. Isolate the pump from the system by closing the valves that should be located on the suction and discharge side of the pump.
3. Loosen pipe plug and drain the pump.
4. Remove all relief, cooling, flushing, or drain lines from the pump. Break suction and discharge connections only if it is desired to remove casing (#6).

⚠ WARNING Hot surface hazard: If pumping hot water, ensure guards or proper insulation is installed to protect against skin contact to hot piping or pump components. Failure to follow these instructions could result in serious personal injury, death or property damage.

⚠ WARNING High pressure hazard: All pumps are designed for specific maximum working pressure. Do not exceed this pressure. Install properly sized pressure relief valves in system. Failure to follow these instructions could result in serious personal injury, death or property damage.

⚠ WARNING Spraying water hazard: When servicing pump replace all gaskets and seals. Do not reuse old gaskets or seals. Failure to follow these instructions could result in serious personal injury, death or property damage.

Notice: For Pentair Aurora 3804 complete pump disassembly continue with step 5, For Pentair Aurora 3801 complete pump disassembly proceed to step 7 on the next page.

5. For Pentair Aurora 3804 pumps, remove the coupling guard.
6. For Pentair Aurora 3804 pumps, loosen the set screws in both coupling halves and slide each half back as far as possible on its shaft. Then, remove the coupling insert. See Figure 41 shown on next page.

PUMP MAINTENANCE AND SERVICE

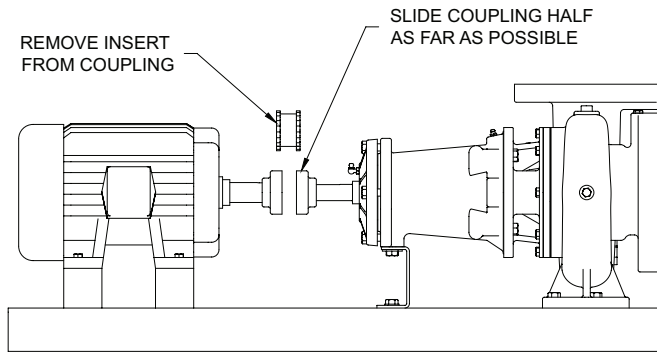

Figure 41

Pentair Aurora® 3804-frame mounted pump assembly

7. Remove the foot support cap screws of power frame (for 3804)/ motor (for 3801).
8. Loosen the casing cap screws (#5) connecting the seal plate (#35A). Do not remove them. Utilize two casing bolts to jack the power frame assembly (for 3804)/ motor assembly (for 3801) out from the casing (#6).
9. Utilize suitable lifting equipment to lift the motor assembly out from the casing.
10. Utilize suitable lifting equipment to lift the power frame assembly (for 3804)/ motor assembly (for 3801) out from the casing.
11. Remove impeller (#11).
12. Remove impeller key (#12).
13. Slide sleeve (#25) and O-ring (#10) with the rotating parts of the mechanical seal (Refer Figure 42) from the shaft. See Figure 43.

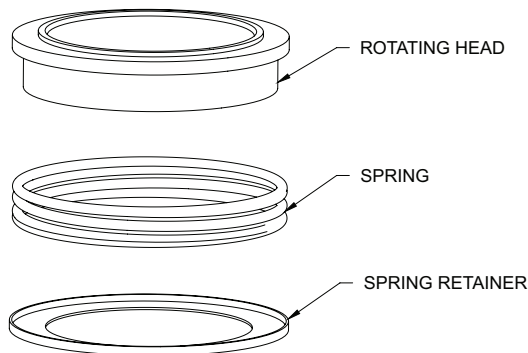
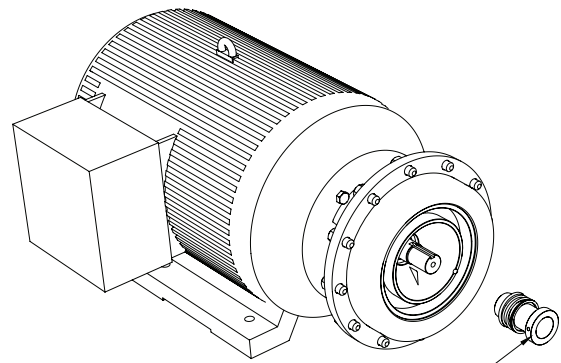

Figure 42

Rotating parts of mechanical seal



SLEEVE REMOVED WITH ROTATING PART OF MECHANICAL SEAL

Figure 43

14. Unscrew cap screws (#5B) holding motor bracket (#35B) and seal plate (#35A) if any repair is required or for ease of replacing mechanical seal.
15. The seal flexible cup and stationary seat should be pressed out of the seal plate and the cavity cleaned of all residues. Make sure that the seal cavity is not damaged during disassembly since sharp edge can easily damage the elastomer on the mechanical seal during reassembly.

CAUTION The mechanical seal is a precision product and must be treated as such. During removal, great care must be taken to avoid dropping any part of the seal. Take particular care not to scratch the lapped faces on the washer or the sealing seat. Do not put a seal back into service until the sealing faces of the washer and the seat have been lapped or replaced.

Notice: The sleeve should be carefully cleaned to remove any residue that may be remaining in the seal area. The rubber in the seal may have been partially adhered to the sleeve. The sleeve must also be checked for abrasion or corrosion that can occur when fluid residue penetrates between the seal and the sleeve. The sleeve under the seal may be polished lightly to a 32 RMS finish before reassembly. Do not reuse a pitted sleeve. Pin may be removed if necessary.

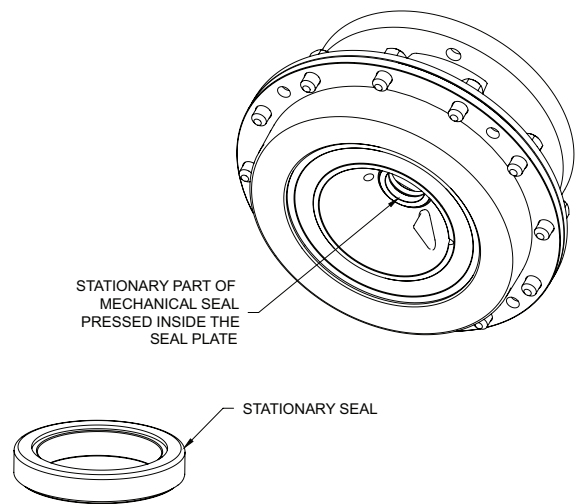

Figure 44

If only mechanical seal is to be replaced, stop at this point and proceed to step 1 under section titled "Installation of the Mechanical Seal - 3801/3804 pumps". Otherwise continue for Pentair Aurora® 3804 complete pump disassembly.

PUMP MAINTENANCE AND SERVICE

Pentair Aurora* 3804 Complete Pump Disassembly or Power Frame Disassembly

Notice: Read and understand all safety warnings at the beginning of the manual before beginning installation or any repair work.

16. Remove the seal plate (#35A) cap screws (#5B) from the bracket (#35B).
17. Remove the power frame cap screws (#5) and washers (#5A) from the bracket (#35B).
If the power frame assembly is being replaced, skip to section titled "Power Frame Reassembly". If replacing the shaft (#55), continue with step 18 for shaft disassembly.
18. Remove the grease fittings (#43) from the power frame.
19. Unscrew cap screws (#48) and remove bearing cap (#49). Remove O-ring (oil lubed only) and retainer ring (#52).
20. Slide out shaft (#55), bearings (#53 and #54). Since bearings (#53 and #54) are press fitted on the shaft, they will have to be pulled or pressed off the shaft. Remove grease seals (#51 & #51A) from frame (#57) and bearing cap (#49) respectively
21. Thoroughly clean the shaft (#55), removing any oil or dirt.

Inspection

Once the pumping unit is disassembled, component parts should be inspected to determine their condition. Ball bearings that turn roughly or show wear should be replaced. Cracked castings should never be used. Scored or worn pump shaft should be replaced. Gaskets should be replaced at reassembly for efficiency. It is recommended to replace routinely than to replace singly as the need arises.

Complete Pump Reassembly - Model 3804/3801

To install mechanical seal skip to step 8 under section "Installation of the Mechanical Seal-3801-3804 Pumps". Otherwise continue with step 1 for "Complete Pump Reassembly - Model 3804/3801".

Power Frame Reassembly

Reassembly will generally be in reverse order of disassembly. If disassembly was not complete, use only those steps related to your particular repair program.

1. Press grease seals (#51 & 51A) into frame (#57) and bearing cap (#49) respectively.
2. Press bearings (#53 & #54) onto shaft (#55).
3. Snap retainer ring (#52) into place.
4. Slide shaft (#55) and bearings (#53 & #54) into frame (#57).
5. Fasten bearing cap (#49) in position with cap screws (#48). Position slingers (#47) on the shaft.
6. Position the bracket (#35B) on the power frame (#57) and secure with cap screws (#5) and washers (#5A). Tighten screws evenly to assure proper alignment.
7. Position the Seal Plate (#35A) on the bracket (#35B) and secure with cap screws (#5B). Tighten screws evenly to assure proper alignment.

Installation of the Mechanical Seal-3801-3804 Pumps

8. Thoroughly clean the shaft sleeve and seal plate seal cavity. Replace the shaft sleeve (#25) or seal plate (#35A) if there is evidence of surface damage like pitting, corrosion, nicks or scratches.
9. Lubricate the shaft sleeve (#25) and seal plate (#35A) with soap and water or P-80™ rubber emulsion. Do not use petroleum lubricant. Install a new insert gasket and a new seal (#27) insert down into the seal plate.

10. Slide a new rotating seal assembly (#27) on to the shaft sleeve. With a screwdriver, push the top of the compression ring until the seal is tight against the seal insert. Install seal spring.

Notice: Refer to Table 2 "Seal Kit Selection Matrix" on Page 17 to determine the seal kit to be used for repair in relation to the power frame assembly for Pentair Aurora 3804- frame mounted pumps.

CAUTION The mechanical seal (#27) is a precision product and must be treated as such. During installation, great care must be taken to avoid dropping any part of the seal. Take particular care not to scratch the lapped faces on the washer or the sealing seat.

11. Install O-ring (#10).
12. Install a new impeller key (#12).
13. Install impeller (#11), new impeller washer gasket (#9B), impeller washer (#9A), impeller seal (#9C) and cap screw (#9). Tighten cap screw per torque chart (see Table 4 on Page 18).
14. Install new casing gasket (#8). Then install the pump assembly into the volute.
15. Tighten volute cap screws (#5) per torque chart (see Table 4 on Page 18).
16. For Pentair Aurora 3804 pumps, install foot support cap screws (#62)
17. For Pentair Aurora 3804 pumps, install coupling and align. (Follow coupling alignment procedure "Shaft/Coupling Alignment" on Page 12).
18. Install drain plugs, close drain valve.
19. For Pentair Aurora 3804 pumps, reinstall the coupling guard.
20. Open isolation valves and inspect pump for leaks.
21. Return pump to service.

CAUTION Do not start pump until all air and vapor has been bled and until making sure that there is liquid in the pump to provide the necessary lubrication for the packing.

Notice: WHEN ORDERING SPARE PARTS ALWAYS INCLUDE THE PUMP TYPE, SIZE, SERIAL NUMBER, AND THE PIECE NUMBER FROM THE EXPLODED VIEW IN THIS MANUAL. ORDER ALL PARTS FROM YOUR LOCAL AUTHORIZED DISTRIBUTOR OR PENTAIR AURORA CUSTOMER SERVICE.

PENTAIR AURORA RESERVES THE RIGHT TO SUBSTITUTE MATERIALS WITHOUT NOTICE.

TROUBLESHOOTING GUIDE

THE FOLLOWING IS A LIST OF COMMON PROBLEMS AND THEIR PROBABLE CAUSES.

Symptoms	Possible causes	Possible remedies	
Insufficient pressure or Insufficient/no flow	Speed too low	Check and ensure correct voltage at motor terminals	
		Check if rotating elements freely rotate	
	Wrong direction of rotation	Check motor rotation with direction arrow on casing	
		Ensure correct motor wiring	
	Entrained air in pump	Ensure all air is vented, and pump is adequately primed	
		Ensure eccentric reducer, if correctly installed	
	Air leaks into suction line	Tighten the suction piping flange bolts as required	
	Leaking joints	Check for any external leakage and arrest	
	Excessive leakage from seal	Inspect and replace mechanical seal, as required	
	Insufficient submergence of suction pipe	Check and ensure sufficient pipe length, submerged well below the water surface	
	Insufficient pressure at pump inlet	Ensure correct suction pipe sizing	
		Raise fluid level or move pump closer to the water level	
		Clogged impeller	Clean impeller as required
		Damaged impeller	Check and replace impeller as required
	Worn wear rings	Check and replace wear rings, if equipped	
	System head not as anticipated	Contact manufacturer for correct pump sizing	
	Smaller impeller diameter	Contact manufacturer for correct impeller sizing	
Excessive power consumption	Speed too high	Check and ensure correct voltage at motor terminals	
	Rubbing or binding of rotating elements	Check if rotating elements are not rubbing against stationary components	
	Shaft bent	Inspect shaft for any deformation and replace	
	Worn wear rings	Check and replace wear rings, if equipped	
	Head lower than rating, pumps too much liquid	Contact manufacturer for correct pump/impeller sizing	
Abnormal noise and vibration	Coupling misalignment	Check and ensure alignment between pump and driver shaft	
	Foundation/grouting not rigid	Ensure foundation is adequately sized and rigid to absorb the vibrations	
		Ensure foundation bolts are tightened to adequate torque	
	Defective bearings	Check motor and/or pump for worn bearings, and replace as required	
	Rubbing or binding of rotating elements	Check if rotating elements are not rubbing against stationary components	
	Pump operating outside Allowable Operating Region (AOR)	Ensure the pump is being operated within its Allowable Operating region. Contact manufacturer for correct pump sizing.	
	Entrained air in pump	Ensure all air is vented, and pump is adequately primed	
	Ensure eccentric reducer, if correctly installed		
Insufficient pressure at pump inlet	Ensure correct suction pipe sizing		
	Raise fluid level or move pump closer to the water level		

TROUBLESHOOTING GUIDE

Motor fails to start	Incorrect wiring	Check motor wiring against motor wiring diagram (on motor)
	Wrong voltage	Check and ensure correct voltage at motor terminals
	Switches not set	Set switches ON
	Tripped thermal overload relay	Set relays ON
	Blown fuses	Replace fuses
	Loose or broken wiring	Check and tighten connections. Replace broken wiring
	Binding of rotating elements	Check if rotating elements freely rotate
	Defective motor	Check and replace motor
Motor runs hot	Speed too high	Check and ensure correct voltage at motor terminals
	Voltage lower than rated	Check and ensure correct voltage at motor terminals
	Rubbing or binding of rotating elements	Check if rotating elements are not rubbing against stationary components

Note: The pump delivered may not be fitted with all the components mentioned in the troubleshooting guide.

ASSEMBLY EXPLODED VIEW

PENTAIR AURORA* MODEL 3801 CLOSE COUPLED CONFIGURATION

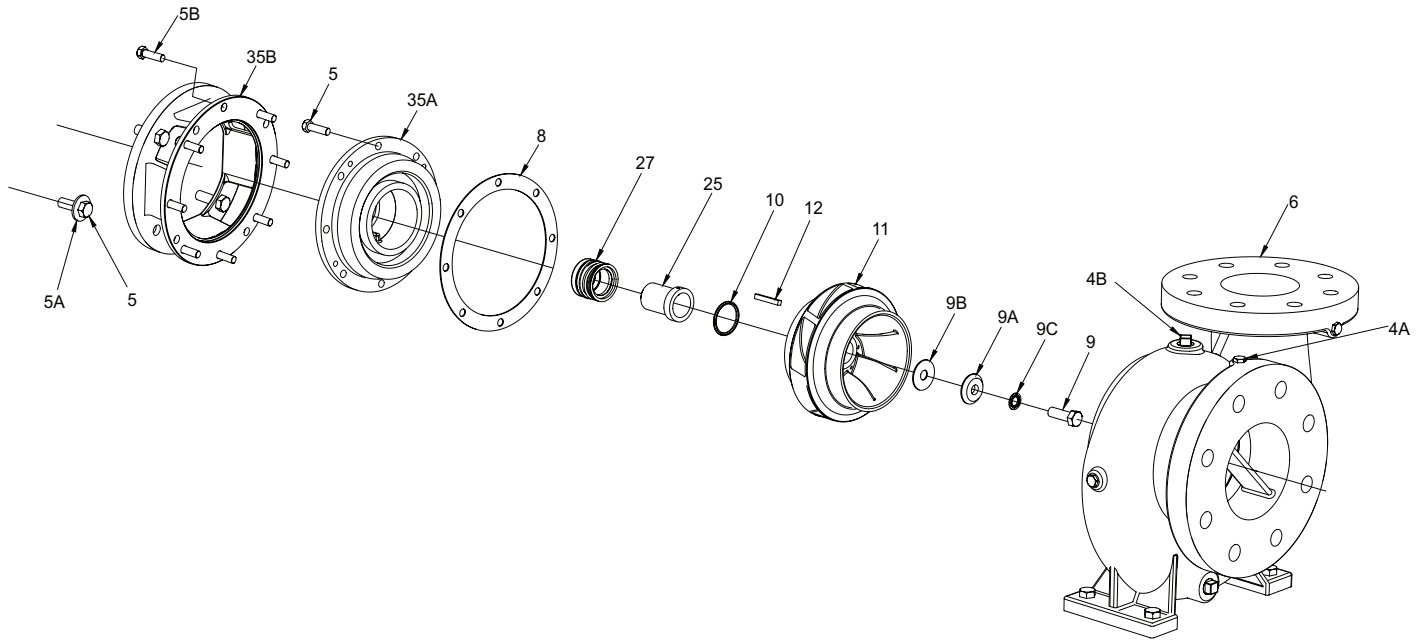

Figure 45
Pentair Aurora Model 3801, close coupled configuration

ASSEMBLY EXPLODED VIEW

PENTAIR AURORA* MODEL 3804 FRAME MOUNTED CONFIGURATION

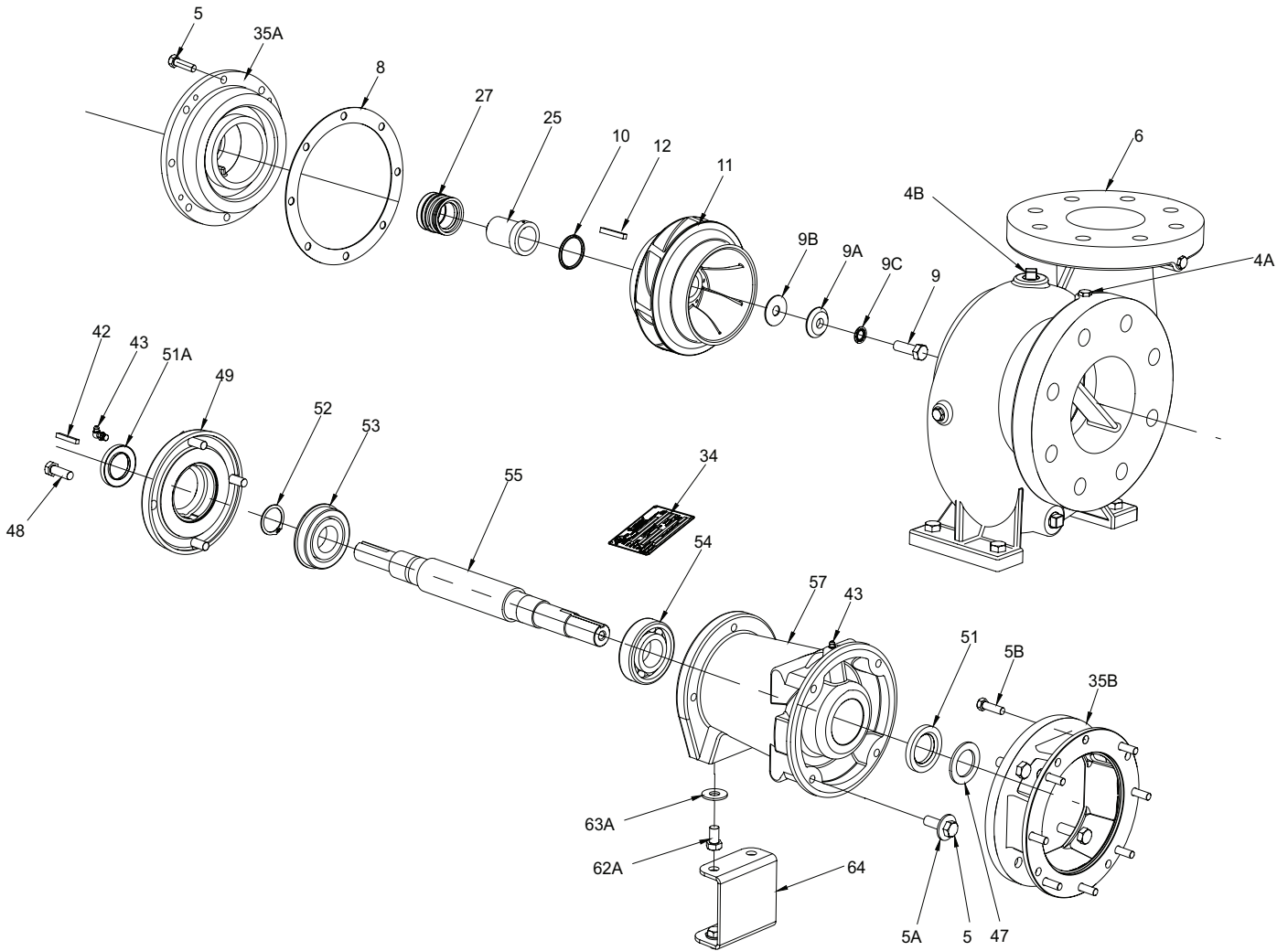

Figure 46
Pentair Aurora Model 3804, frame mounted configuration

PART LIST

PENTAIR AURORA* 3801 AND 3804

Reference: Figure 45, 46(Exploded Views)

ITEM NO.	DESCRIPTION
4	Pipe plug
4A/B.	Cap screw
5A.	Cap screw washer
5B.	Cap screw
6	Casing
8	Gasket
9	Impeller screw
9A.	Impeller washer
9B.	Impeller gasket
9C.	Impeller seal
10	O-ring
11	Impeller
12	Impeller key
25	Sleeve
27	Mechanical seal
32	Cap screw
33	Screw
34	Nameplate
35A.	Seal plate
35B.	Motor bracket
42	Key
43	Grease fitting
47	Slinger
48	Cap screw
49	Bearing cap
52	Retaining ring
53	Bearing
54	Bearing
55	Shaft
57	Power frame
62A.	Cap screw
62B.	Nut
63	Washer
64A/B.	Foot support

STANDARD LIMITED WARRANTY

LIMITED WARRANTY

Seller warrants equipment (and its component parts) of its own manufacture against defects in materials and workmanship under normal use and service for one (1) year from the date of installation or start-up, or for eighteen (18) months after the date of shipment, whichever occurs first. Seller warrants 3800 series end suction pump models for a period of five (5) years from the date of installation or start-up, or for sixty (60) months after the date of shipment, whichever comes first. Seller does not warrant accessories or components that are not manufactured by Seller; however, to the extent possible, Seller agrees to assign to Buyer its rights under the original manufacturer's warranty, without recourse to Seller. Buyer must give Seller notice in writing of any alleged defect covered by this warranty (together with all identifying details, including the serial number, the type of equipment, and the date of purchase) within thirty (30) days of the discovery of such defect during the warranty period. No claim made more than 30 days after the expiration of the warranty period shall be valid. Guarantees of performance and warranties are based on the use of original equipment manufactured (OEM) replacement parts. Seller assumes no responsibility or liability if alterations, non-authorized design modifications and/or non-OEM replacement parts are incorporated. If requested by Seller, any equipment (or its component parts) must be promptly returned to Seller prior to any attempted repair, or sent to an authorized service station designated by Seller, and Buyer shall prepay all shipping expenses. Seller shall not be liable for any loss or damage to goods in transit, nor will any warranty claim be valid unless the returned goods are received intact and undamaged as a result of shipment. Repaired or replaced material returned to customer will be shipped F.O.B., Seller's factory. Seller will not give Buyer credit for parts or equipment returned to Seller, and will not accept delivery of any such parts or equipment, unless Buyer has obtained Seller's approval in writing. The warranty extends to repaired or replaced parts of Seller's manufacture for ninety (90) days or for the remainder of the original warranty period applicable to the equipment or parts being repaired or replaced, whichever is greater. This warranty applies to the repaired or replaced part and is not extended to the product or any other component of the product being repaired. Repair parts of its own manufacture sold after the original warranty period are warranted for a period of one (1) year from shipment against defects in materials and workmanship under normal use and service. This warranty applies to the replacement part only and is not extended to the product or any other component of the product being repaired. Seller may substitute new equipment or improve part(s) of any equipment judged defective without further liability. All repairs or services performed by Seller, which are not covered by this warranty, will be charged in accordance with Seller's standard prices then in effect.

THIS WARRANTY IS THE SOLE WARRANTY OF SELLER AND SELLER HEREBY EXPRESSLY DISCLAIMS AND BUYER WAIVES ALL OTHER WARRANTIES EXPRESSED, IMPLIED IN LAW OR IMPLIED IN FACT, INCLUDING ANY WARRANTIES OF MERCHANTABILITY OR FITNESS FOR A PARTICULAR PURPOSE. Seller's sole obligation under this warranty shall be, at its option, to repair or replace any equipment (or its component parts) that has a defect covered by this warranty, or to refund the purchase price of such equipment or part. Under the terms of this warranty, Seller shall not be liable for (a) consequential, collateral, special or liquidated losses or damages; (b) equipment conditions caused by normal wear and tear, abnormal conditions of use, accident, neglect, or misuse of said equipment; (c) the expense of, and loss or damage caused by, repairs or alterations made by anyone other than the Seller; (d) damage caused by abrasive materials, chemicals, scale deposits, corrosion, lightning, improper voltage, mishandling, or other similar conditions; (e) any loss, damage, or expense relating to or resulting from installation, removal or reinstallation of equipment; (f) any labor costs or charges incurred in repairing or replacing defective equipment or parts, including the cost of reinstalling parts that are repaired or replaced by Seller; (g) any expense of shipment of equipment or repaired or replacement parts; or (h) any other loss, damage, or expense of any nature.

The above warranty shall not apply to any equipment that may be separately covered by any alternate or special warranties.

PERFORMANCE: In the absence of Certified Pump Performance Tests, equipment performance is not warranted or guaranteed. Performance curves and other information submitted to Buyer are approximate, and no warranty or guarantee shall be deemed to arise as a result of such submittal. All testing shall be done in accordance with Seller's standard policy under Hydraulic Institute procedures.

LIABILITY LIMITATIONS: Under no circumstances shall the Seller have any liability under the Order or otherwise for liquidated damages or for collateral, consequential, or special damages or for loss of profits, or for actual losses or for loss of production or progress of construction, regardless of the cause of such damages or losses. In any event, Seller's aggregate total liability under the Order or otherwise shall not exceed the contract price.

ACTS OF GOD: Seller shall in no event be liable for delays in delivery of the equipment or other failures to perform caused by fires, acts of God, strikes, labor difficulties, acts of governmental or military authorities, delays in transportation or procuring materials, or causes of any kind beyond Seller's control.

COMPLIANCE WITH LAW: Seller agrees to comply with all United States laws and regulations applicable to the manufacturing of the subject equipment. Such compliance shall include: The Fair Labor Standards Acts of 1938, as amended; Equal Employment Opportunity clauses of Executive Order 11246, as amended; Occupational Safety and Health Act of 1970 and the standards promulgated thereunder, if applicable. Since compliance with the various Federal, State and Local laws and regulations concerning occupational health and safety, pollution, or local codes are affected by the use, installation, and operation of the equipment and other matters over which Seller has no control, Seller assumes no responsibility for compliance with those laws and regulations, whether by way of indemnity, warranty, or otherwise. It is incumbent upon the Buyer to specify equipment that complies with local codes and ordinances.

800 Airport Road
North Aurora, Illinois 60542
630-859-7000



800 Airport Road | North Aurora, Illinois 60542 | Ph: 630.859.7000 | pentair.com

*For a detailed list of where Pentair trademarks are registered, please visit www.pentair.com/en/registrations.html. Pentair trademarks and logos are owned by Pentair PLC, or its affiliates. Third party registered and unregistered trademarks and logos are the property of their respective owners. Because we are continuously improving our products and services, Pentair reserves the right to change specifications without prior notice. Pentair is an equal opportunity employer.

A-03-327 (07/15/21)

©2021 Pentair. All Rights Reserved.